



PRODUCT OPERATING MANUAL

PANBLAST™

BP110-1 BLAST POT

Manual Number: ZVP-PC-0116-00

SECTION

1. **GENERAL INFORMATION**
2. **INITIAL SETUP INSTRUCTIONS**
3. **OPERATING INSTRUCTIONS**
4. **MAINTENANCE**
5. **TROUBLE SHOOTING GUIDE**
6. **ASSEMBLIES, PARTS LISTING & EXPLODED VIEW**
7. **COPY OF BLAST POT SHELL CERTIFICATE (IF APPLICABLE)**

BLAST POT SERIAL NUMBER:

1.0 GENERAL INFORMATION

1.1 Panblast notice to purchasers and users

1.1.1 All products and equipment designed and manufactured by Panblast are intended for use by experienced users of abrasive blasting equipment and its associated operations and abrasive blasting media.

1.1.2 It is the responsibility of the user to:

- Determine if the equipment and abrasive media is suitable for the users' intended use and application.
- Familiarize themselves with any appropriate laws, regulations and safe work practices, which may apply within the users working environment.
- Provide appropriate operator training and a safe working environment including operator protective equipment such as, but not limited to, safety footwear, protective eyewear and hearing protection.

1.1.3 Panblast Standard Terms and Conditions of Sale apply. Contact your local Panblast office should you require any further information or assistance.

1.2  **! WARNING! - READ THIS SECTION CAREFULLY BEFORE USING THIS EQUIPMENT / APPARATUS.**

1.2.1 Heavy metal paint, asbestos and other toxic material dusts will cause serious lung disease or death without the use of properly designed and approved supplied air respiratory (SAR) equipment by blast operators and all personnel within the work site area.

1.2.2 The compressor must have adequate output and the plumbing between the compressor and the point of attaching the air supply hose must have sufficient capacity to supply the volume of air at the pressure required.

1.3 Standard safety precautions

1.3.1 Approved safety eyewear, hearing and footwear protection should be worn at all times by the operator and any personnel in the immediate area that may be exposed to any hazards generated by the abrasive blasting process.

1.3.2 Suitably approved respiratory protection should also be worn when handling abrasive media, abrasive refuse dust and when carrying out any service/maintenance work where any dust may be present.

1.3.3 Any work performed on electrical wiring or components must only be carried out by suitably qualified and registered electrical personnel.

1.3.4 Under no circumstances should any safety interlocks / lockouts or features be altered or disabled in any way.

1.3.5 All equipment must be isolated from the compressed air supply and electrical power prior to any service or maintenance work being carried out.

1.3.6 All care must be taken by the operator(s) when lifting or moving equipment or components in order to prevent injury. Blast pots must always be emptied of abrasive media before any attempt is made to move them.

1.3.7 Any modification of the equipment or use of non-genuine PanBlast™ replacement parts will void warranty.

1.3.8 Always check the Material Safety Data Sheet (MSDS) on the abrasive media being used to ensure that it is free of harmful substances, in particular, free silica, cyanide, arsenic or lead.

1.3.9 Test the surface to be blasted for harmful substances, taking the appropriate measures to ensure the safety of all personnel.

1.3.10 The operator should carry out a daily inspection of all related components prior to startup of all wearing and safety items to ensure they are in correct operating order. In particular check all hose couplings and nozzle holders, ensuring that all hose couplings are fitted correctly, the safety locking pins are engaged and in good order. Always install safety whip check cables at every hose connection. Ensure that the blast nozzle has been securely screwed into the nozzle holder and the nozzle holder has been secured to the blast hose correctly and all screws are engaged.

NOTE: UNDER OSHA 1915:34(c)(1)(iv) DEAD MAN CONTROL. A DEADMAN CONTROL DEVICE SHALL BE PROVIDED AT THE NOZZLE END OF THE BLAST HOSE EITHER TO PROVIDE DIRECT CUTOFF OR TO SIGNAL THE POT TENDER BY MEANS OF A VISUAL AND AUDIBLE SIGNAL TO CUT OFF THE FLOW, IN THE EVENT THE BLASTER LOSES CONTROL OF THE HOSE. THE POT TENDER SHALL BE AVAILABLE AT ALL TIMES TO RESPOND IMMEDIATELY TO THE SIGNAL.

2.0 INITIAL SET UP INSTRUCTIONS

2.1 Blast pot initial set up

2.1.1 Position the blast pot in the location where it is to be used, preferably on a flat, level surface. Never attempt to move the blast pot when it is full of abrasive media.

2.1.2 Fit the blast hose coupling and nozzle holder to the blast hose, ensuring that the ends of the blast hose are cut square and flat. The blast hose coupling and nozzle holder must be pushed/twisted up onto the blast hose until the end of the blast hose is firmly up against the inside step located inside the blast hose coupling and nozzle holder.

Then install the screws supplied with the blast hose coupling and nozzle holder to ensure that they are securely fitted to the blast hose.

 ! WARNING! - NEVER OPERATE/USE A BLAST HOSE WITHOUT THE BLAST HOSE COUPLING AND NOZZLE HOLDER FITTED IN THE CORRECT MANNER.

2.1.3 Once fitment of the blast hose fittings is complete, connect the blast hose coupling to the abrasive metering valve coupling located on the bottom of the blast pot, making sure that the coupling safety lock pins are correctly fitted and form an airtight seal between the two couplings. Proceed by laying the blast hose out flat to its full length.

2.1.4 Connect the ends of the twinline hose quick connect couplings to the remote control valve

on the blast pot. Then lay the twinline hose out alongside the blast hose for its full length.

- 2.1.5 Using cable ties, heavy tape or similar attach the twinline hose directly to the blast hose at approximately 1000mm (40") intervals. The remote control handle should be cable tied to the blast hose at a point directly behind the previously fitted nozzle holder.
- 2.1.6 Securely attach a suitably sized compressed air line to the blast pot main air supply inlet ball valve, ensuring that the air supply ball valve is in the closed position. It is preferable for the compressed air line to be at least one size larger than the piping size on the blast pot. Ensure that all coupling safety locking pins and/or locks are correctly fitted to the compressed air connection. Panblast recommends the use of correctly sized safety whip check cables on all compressed air line and blast hose connections.
- 2.1.7 Check that the nozzle holder rubber washer is correctly installed then screw the blast nozzle fully into the nozzle holder, ensuring that it forms a seal against the nozzle rubber washer.

3.0 BLAST POT OPERATING INSTRUCTIONS

3.1 Operating instructions

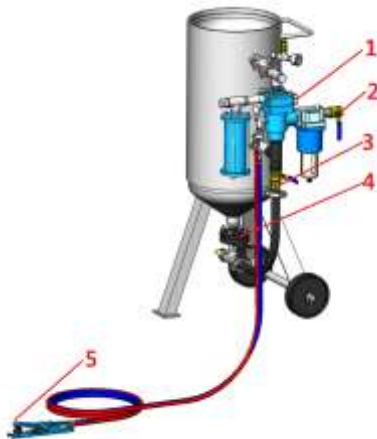

Figure A

- 3.1.1 Ensure that the blast pot has been set up as detailed in Section 2.0 of this manual.
- 3.1.2 Check that the mini ball valve (Figure A. No.1) located on the blast pot UniFlo remote valve assembly is open to prevent accidental pressurization of the blast pot during filling.
- 3.1.3 Check that the main supply ball valve (Figure A. No. 2) is fully closed
- 3.1.4 Check that the choke line ball valve (Figure A. No. 3) is fully open.
- 3.1.5 Fully close the abrasive metering valve (Figure A. No. 4) located on the bottom of the blast pot. The abrasive metering valve is fully CLOSED when the metering handle is positioned in a parallel line to the abrasive inlet feed port
- 3.1.6 Load the abrasive media into the blast pot by pouring it in through the pop up valve opening located in the top of the blast pot. The blast pot screen (where supplied) should be used to prevent coarse debris and oversize particles from entering the blast pot.

NOTE: DO NOT OVERFILL THE BLAST POT. THE ABRASIVE MEDIA LEVEL SHOULD REMAIN BELOW THE BOTTOM OF THE POP UP VALVE TO PREVENT PREMATURE WEAR TO THE REMOTE EXHAUST VALVE ASSEMBLY.

- 3.1.7 Check the remote control handle (Figure A. No. 5) and ensure that the safety lever lock is in the "Up" position and that both the lever handle and safety lever lock move and engage freely.
- 3.1.8 Check that all hose connections, fittings, safety locking pins etc. are all secure and in the correct location.
- 3.1.9 Start the air compressor and allow the compressor to reach the desired operating pressure. Do not set the blast pressure below 345kPa (50psi), as the blast pot system may not operate correctly.

⚠ ! WARNING! - DO NOT EXCEED THE MAXIMUM OPERATING PRESSURE (REFER TO NAMEPLATE AFFIXED TO THE BLAST POT SHELL) OF THE BLAST POT AT ANY TIME AS THIS COULD RESULT IN SERIOUS INJURY OR DEATH.

- 3.1.10 Close the mini ball valve located on the UniFlo remote valve assembly and slowly open the main air supply inlet ball valve on the blast pot and check the piping for air leaks.

NOTE: THE SYSTEM IS NOW READY TO OPERATE AND THE BLAST POT WILL PRESSURIZE IF THE REMOTE CONTROL HANDLE IS ACTIVATED. IT IS NORMAL FOR COMPRESSED AIR TO NOW BLEED FROM THE REMOTE CONTROL HANDLE.

- 3.1.11 Pick up the blast hose at the blast nozzle end and direct the blast nozzle at the surface/part to be abrasive blasted.
- 3.1.12 Pull back the safety lever lock on the remote control handle and then depress the lever handle. After a few moments, the blast pot pop up valve will lift/close, the blast pot will then pressurize and compressed air only will exit the blast nozzle.
- 3.1.13 Have a second person, other than the blasting operator slowly move the lever on the abrasive metering valve from the closed position, until the desired abrasive media flow is achieved. The optimum abrasive media flow level will vary depending on actual operating conditions and the desired end result, but as a general rule, the abrasive media should appear in the air stream as a fine mist. Once the desired abrasive media flow rate has been achieved, the system is now set for the abrasive blasting operation.
- 3.1.14 To stop blasting, release the remote control handle lever. This will de-energize the UniFlo remote valve assembly, which will then exhaust the compressed air from the blast pot through the exhaust port and muffler located on the UniFlo valve assembly and allow the pop up valve to drop open. Check that the remote control handle safety lever lock has flipped to the "Up" position to prevent accidental activation of the blast pot.

3.2 Shutdown procedure

- 3.2.1 Slowly close the main air supply inlet ball valve located on the blast pot.

3.2.2 Open the mini ball valve located on the UniFlo remote valve assembly.

3.2.3 Shut down the air compressor.

3.2.4 Cover the blast pot with the lid (where supplied) and coil up and store the blast hose and twinline hose assembly to prevent accidental damage.

4.0 MAINTENANCE

⚠ ! WARNING! THE COMPRESSED AIR SOURCE MUST BE ISOLATED BEFORE PERFORMING ANY MAINTENANCE WORK. FAILURE TO DO SO MAY CAUSE SERIOUS INJURY OR DEATH.

4.1 On a daily basis

4.1.1 Drain any water/moisture from the compressed air moisture separator located between the main air supply inlet ball valve and the remote control valve (where fitted), by opening the drain valve located on the bottom of the moisture separator bowl.

Unscrew the retaining ring and remove the moisture separator bowl. Check the internal filter element for blockages and replace as required.

Re-fit the bowl and locking ring and close the bowl drain valve.

NOTE: IT IS RECOMMENDED THE INCOMING PRESSURIZED AIR IS EQUIPPED WITH A DRYER SYSTEM TO ENSURE THE INLET AIR IS DRY.

4.1.2 Inspect the blast hose for wear by feeling along its full length for soft spots, which indicate internal wear, replace the blast hose as necessary.

4.1.3 Check all blast hose couplings and nozzle holder are secure and that all safety locking pins and safety whip check cables are correctly in place.

4.1.4 Remove the safety locking pins and disconnect the couplings by twisting the coupling counter clockwise. Inspect the coupling gaskets for wear and correct seating. Replace the coupling gaskets as required. Reconnect the couplings by engaging the lugs with the blast pot coupling and twisting the blast hose coupling clockwise until fully engaged, ensure all the safety locking pins are in place.

4.1.5 Inspect the AirFlo Remote Control Handle, and check that the lever handle and safety lever lock assembly operate correctly and that the safety lever lock prevents operation of the remote control handle when in the "Up" position.

4.2 On a weekly basis

4.2.1 Remove the blast nozzle from the nozzle holder by unscrewing the blast nozzle in a counter clockwise direction and inspect it for wear. Replace the blast nozzle if or when the internal diameter is worn by 1.5mm (1/16") from its original size, or if the liner is chipped or cracked.

4.2.2 Check the condition of the nozzle washer and replace as required, then re-fit/replace the blast nozzle by screwing it clockwise into the nozzle holder until it is fully sealed against the nozzle washer.

4.2.3 Check the condition of the nozzle holder and inspect for any cracks or signs of damage. Replace if required as detailed in Section 2.1.2

4.3 On a monthly basis

4.3.1 Inspect the pop up valve located in the top of the blast pot for wear in the form of cracks or grooves. If replacement is required, remove the blast pot shell inspection cover located on the blast pot. Using a suitable pipe wrench, unscrew the vertical pipe section, which houses the pop up valve, and remove both the pipe section and pop up valve through the inspection opening.

Installation of the new pop up valve is a reversal of the removal procedure. Ensure that the pop up valve is positioned directly below the top opening of the blast pot for correct sealing.



Figure B

4.3.2 Check and inspect the pop up valve seating ring for wear. If replacement is necessary use a large screwdriver or similar tool to pry the seating ring out of the housing. When re-fitting the new seating ring ensure that it is correctly seated within the seating ring housing.



Figure C

4.3.3 Inspect the blast pot exhaust muffler and exhaust line for wear or blockages. If replacement is required, remove the muffler from the blast pot pipe work. When replacing, ensure all pipe connections and fittings are secure and fully tightened.

4.3.4 Loosen the hose clamps on the small section of hose located between the top of the UniFlo valve assembly, remove the four (4) UniFlo Control Valve exhaust chamber retaining bolts and remove the UniFlo valve exhaust chamber. Inspect the exhaust pad, diaphragm, piston and exhaust chamber and nipple for wear. These items should be replaced if the wear is sufficient to prevent the exhaust pad from sealing correctly against the nipple. Inspect the diaphragm for signs of tears or deterioration and replace if required.

Re-fitting is a reversal of the removal procedure. Ensure that the exhaust pad is fully seated in the piston and the diaphragm is centrally located in the valve housing.

5.0 TROUBLE SHOOTING GUIDE

Item	Problem	Possible Cause	Corrective Action
1	Blast Pot will not pressurize	No compressed air supply.	Check air compressor for operation.
		Main air supply inlet ball valve closed.	Open air supply inlet ball valve.
		Pop up valve or seating ring worn or damaged.	Inspect and replace as required.
		Inadequate compressed air supply.	Check compressor output and supply hose size to blast pot.
2	No air and /or abrasive flow from Blast Nozzle	Blast nozzle blocked.	Depressurize system, remove blast nozzle from nozzle holder, clear blockage and re-fit blast nozzle.
		Pusher line choke valve fully closed.	Open and adjust choke valve as required.
		Abrasive metering valve fully closed.	Open and adjust abrasive metering valve as required.
		Pop up valve and seating ring worn or damaged.	Inspect and replace as required.
		Insufficient abrasive media in blast pot.	Re-fill with abrasive media as required.
		Excessive dust and fines in abrasive mix.	Drain abrasive media from blast pot and re-fill with clean abrasive media.
		Damp or wet abrasive media in blast pot.	Drain abrasive media from blast pot and re-fill with clean abrasive media.
		Leak or loose fittings in twinline hose.	Inspect twinline hose and tighten fittings as required.
		Remote control valves not operating.	Disassemble valves; inspect seals and diaphragm for wear. Replace as necessary.
3	Intermittent abrasive media flow	Excessive dust and fines in abrasive mix.	Drain abrasive media from blast pot and re-fill with clean abrasive media.
		Insufficient abrasive media in blast pot.	Re-fill with abrasive media as required.
		Damp or wet abrasive media in blast pot.	Drain abrasive media from blast pot and re-fill with clean abrasive media.
		Compressed air supply pressure too low.	Check and adjust air pressure as required.
4	Excessive abrasive flow	Pusher line choke valve fully closed.	Open and adjust choke valve as required.
		Abrasive metering valve fully opened.	Adjust abrasive metering valve as required.
5	Excessive wear on Blast Hose	Blast hose kinked or coiled.	Keep blast hose as straight as possible without being coiled.
		Blast nozzle excessively worn.	Check blast nozzle internal diameter and replace as required.
6	Excessive wear on Remote Control Valve parts	Blast pot being overfilled.	Only re-fill blast pot to specified level.
		Blast pot being depressurized and re-pressurized too frequently.	Operate blast pot as efficiently as possible to keep cycling to a minimum.

6.0 ASSEMBLIES, PARTS LISTING & EXPLODED VIEW

6.1 BP110-1 Blast Pot Assemblies

Stock Code	Description	Dry Weight	Abrasive Capacity
BEP-PS-PB-0019	BP110-1/AU UniFlo J/Plana AirFlo 150PSI	70kg (155lbs)	31Litres (1.1ft ³)
BEP-PS-0065-00	BP110-1/SG UnFlo J/Plana AirFlo	70kg (155lbs)	31Litres (1.1ft ³)
BEP-PS-0074-00	BP110-1/AU/NZ/MY UniFlo J/Plana AirFlo	70kg (155lbs)	31Litres (1.1ft ³)

6.1.1 BP110-1 Blast Pot Parts Listing

Item	Stock Code	Description	Qty
1	BAC-RC-0527-00	UniFlo Valve With Fittings - 90 Deg	1
2	BAC-VA-0335-00	Junior Plana NPT Valve	1
3	BAC-RC-PB-0013	10m (33') Twinline Hose Assembly	1
4	BAC-RC-PB-0085	AirFlo Pneumatic Control Handle	1
5	YAC-RC-0487-00	Exhaust Muffler	1
6	BAC-PF-PB-0004	19mm (3/4") Ball Valve	2
7	BAC-HC-0086-00	STC-1/2 Steel Threaded Pot Coupling	1
8	BAC-PF-PB-0031	6mm (1/4") Pressure Gauge - Rear Entry	1
9	BAC-PF-PB-0030	6mm (1/4") 125psi Pressure Relief Valve	1
10	BAC-BF-PB-0013	Pop Up Valve Seating Ring	1
11	BAC-BF-PB-0012	Pop Up Valve - Stem Type	1
12	BAC-AF-PB-0057	19mm(3/4") Port Moisture Separator	1
13	YAC-FN-PB-0242	Hose Clamp	2
14	YAC-PF-PB-0186	KC Nipple	2
15	YAC-BF-PB-0041	Hose-Air/Water Delivery 19mmIDX29mmOD	0.7 MTR
16	YAC-BF-0231-00	Blast Pot-H/Hole 192x144-Sealing Gasket	1

6.1.2 BP110-1 Blast Pot Exploded View

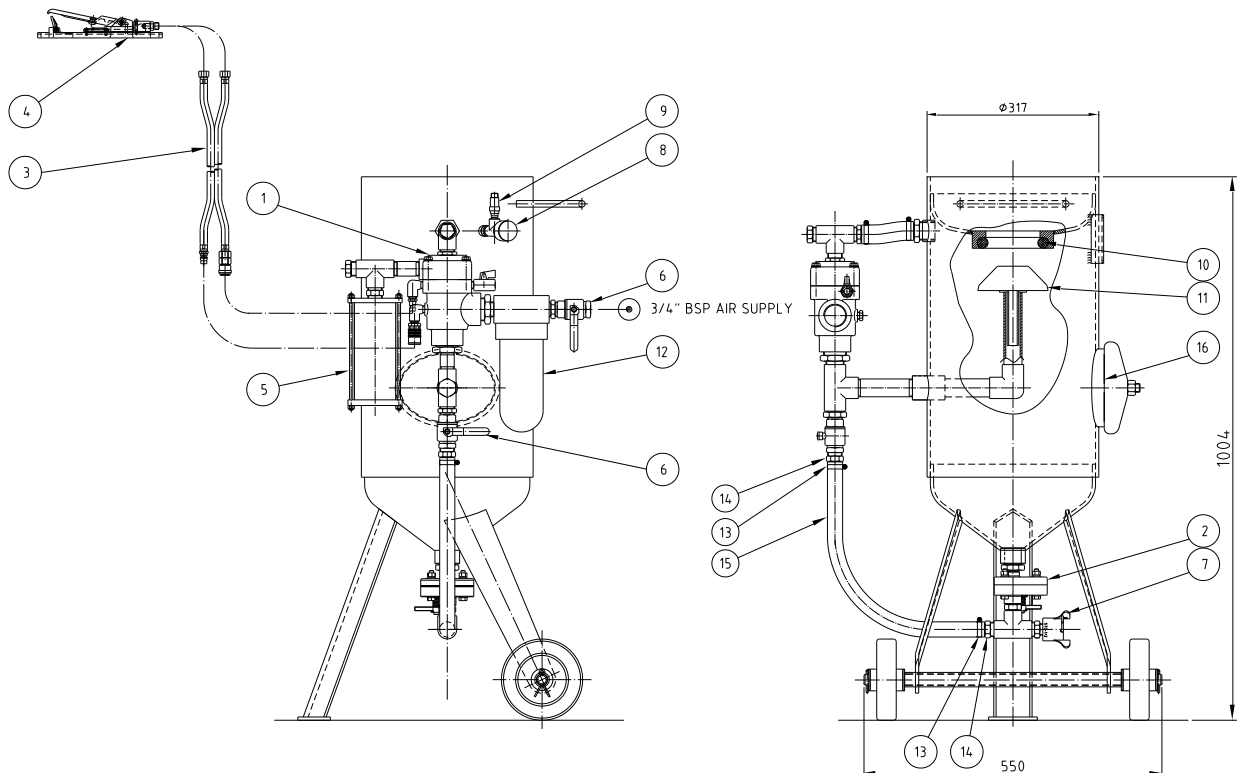

6.2 UniFlo Valve Assembly

Stock Code	Description	Weight
BAC-RC-0527-00	Uniflo Valve With Fittings - 90 Deg	2.50kg (5.51lbs)

6.2.1 UniFlo Valve Parts Listing

Item	Stock Code	Description	Qty
1	YAC-RC-PB-0068	Body	1
2	BAC-RC-PB-0069	Exhaust Chamber	1
3	YAC-RC-PB-0070	Exhaust Pad	1
4	YAC-RC-PB-0071	Piston	1
5	YAC-RC-PB-0072	Diaphragm	1
6	YAC-RC-PB-0073	Backing Washer	1
7	YAC-RC-PB-0074	Piston Rod	1
8	YAC-RC-PB-0075	Bush	1
9	YAC-RC-PB-0076	Spring	1
10	YAC-RC-PB-0077	Piston End Cap	1
11	YAC-RC-PB-0078	Retaining Disk	1
12	YAC-FN-PB-0100	Screw	2
13	YAC-FN-PB-0101	Circlip	1
14	YAC-BS-PB-0012	O-Ring	1
15	YAC-BS-PB-0006	O-Ring	1
16	YAC-BS-PB-0005	O-Ring	1
17	YAC-FN-PB-0102	Hex Head Bolt	4
18	YAC-FN-PB-0022	Flat Washer	4
19	YAC-RC-PB-0083	Nipple - Customized	1
20	YAC-RC-PB-0095	Lock Nut	1
21	YAC-PF-0367-00	Elbow M & F	2
22	YAC-PF-PB-0068	Quick Disconnect Fitting Female	1
23	YAC-PF-PB-0069	Quick Disconnect Fitting Male	1
24	YAC-PF-PB-0167	Mini Ball Valve	1
25	YAC-PF-PB-0088	Plug	1

6.2.2 UniFlo Valve Service Kits

Stock Code	Description
BAC-RC-PB-0092	Uniflo Seal Service Kit - Includes Items 3, 5, 14, 15 & 16
BAC-RC-PB-0004	Uniflo Pneumatic Fittings Kit - Includes Items 19, 20, 22, 23, 24 & 25
BAC-RC-PB-0005	Uniflo Piston Service Kit - Includes Items 4, 6, 7, 8, 9, 10, 11, 12 (2 Off), 13, 17 (4 Off) & 18 (4 Off)
BAC-RC-PB-0097	Uniflo Top End Service Kit - Includes Items 3, 4, 5 & 19
BAC-RC-PB-0098	Uniflo Exhaust Pad Kit - Includes Items 3 (3 Off)
BAC-RC-PB-0099	Uniflo Diaphragm Pad Kit - Includes Items 5 (3 Off)

6.2.3 UniFlo Valve Exploded View

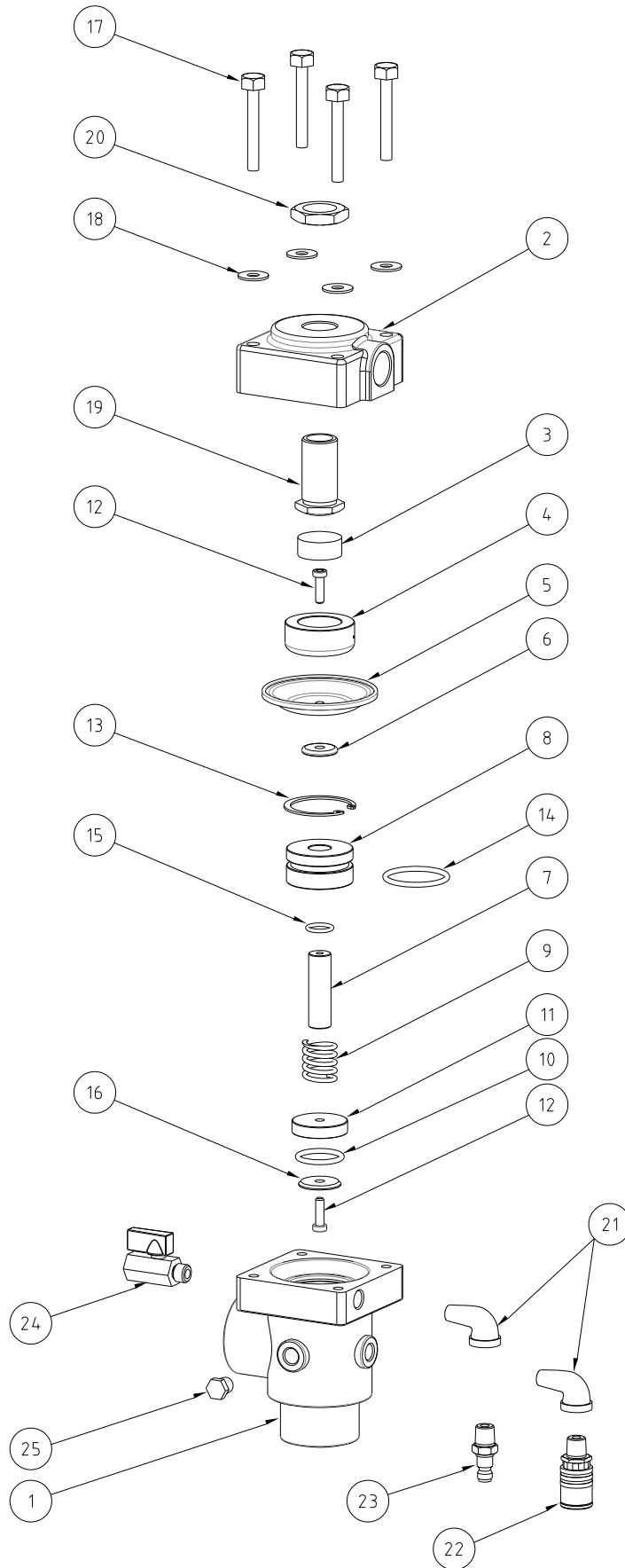

6.3 AirFlo Pneumatic Control Handle Assembly

Stock Code	Description	Weight
BAC-RC-PB-0085	AirFlo Pneumatic Control Handle	0.40Kg (0.88lbs)

6.3.1 AirFlo Pneumatic Control Handle Parts Listing

Item	Stock Code	Description	Qty
1	YAC-RC-PB-0058	AirFlo Handle -- Body	1
2	BAC-RC-PB-0059	Lever	1
3	YAC-RC-PB-0060	Pneumatic Manifold	1
4	YAC-RC-PB-0061	Lever Safety Lock	1
5	YAC-RC-PB-0062	Gasket	1
6	YAC-RC-PB-0063	Bumper Button	1
7	YAC-RC-PB-0064	Nipple - Restricted	1
8	YAC-RC-PB-0087	Nipple - Un-restricted	1
9	YAC-RC-PB-0065	Safety Lock Spring	1
10	YAC-RC-PB-0066	Screw	2
11	YAC-FN-PB-0158	Screw	2
12	YAC-FN-PB-0159	Screw	4
13	YAC-FN-PB-0141	Lock Nut	2
14	YAC-RC-PB-0067	Lever Spring	1

6.3.2 AirFlo Pneumatic Control Handle Service Kits

Stock Code	Description
BAC-RC-PB-0011	AirFlo Handle Service Kit - Includes items 2, 4, 5, 6 (6 Off), 9 & 14
BAC-RC-PB-0116	AirFlo Bumper Kit - Includes items 6 (6 Off)
BAC-RC-PB-0117	AirFlo Lever Spring Kit - Includes items 15 (6 Off)

6.3.3 AirFlo Pneumatic Control Handle Exploded View

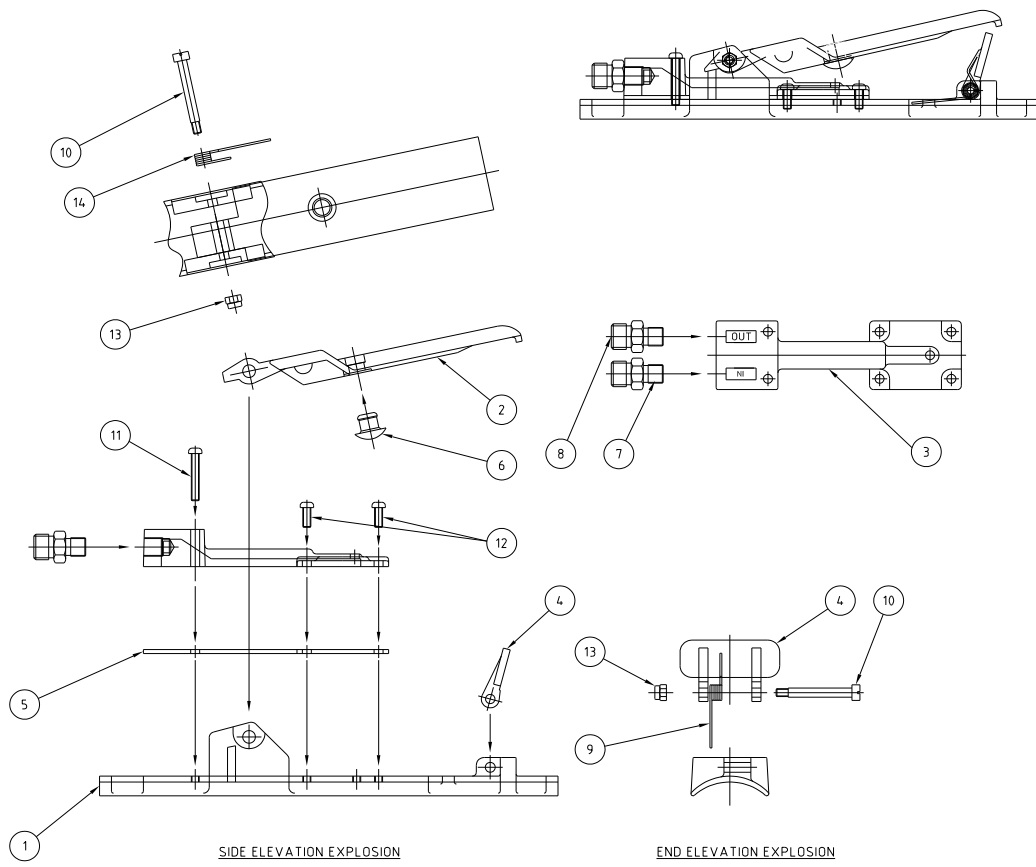

6.4 Junior Plana NPT Valve Assembly

Stock Code	Description	Weight
BAC-VA-0335-00	Junior Plana NPT Valve	2.60Kg (5.73lbs)

6.4.1 Junior Plana NPT Valve Parts Listing

Item	Stock Code	Description	Qty
1	YAC-FN-0337-00	5/16" UNC Nut	4
2	YAC-FN-PB-0021	Spring Washer	4
3	YAC-FN-PB-0022	Flat Washer	8
4	YAC-VA-0339-00	Lower Body - NPT	1
5	YAC-VA-0340-00	Control Plate	1
6	YAC-VA-0341-00	Nylon Washer	1
7	YAC-BS-PB-0003	O-Ring	1
8	YAC-VA-0342-00	Rubber Gasket	1
9	YAC-VA-0343-00	Upper Body - NPT	1
10	YAC-FN-0338-00	Hex Head Bolt	4
11	YAC-RC-PB-0129	Spring	1
12	YAC-VA-0344-00	Handle	1
13	YAC-FN-0339-00	Spring Pin	1

6.4.2 Junior Plana NPT Valve Exploded View

