



# **PRODUCT OPERATING MANUAL**

**PANBLAST™**

***BP316-2 BLAST POT***

***Manual Number: ZVP-PC-0152-00***

**SECTION**

- 1. GENERAL INFORMATION**
- 2. INITIAL SETUP INSTRUCTIONS**
- 3. OPERATING INSTRUCTIONS**
- 4. MAINTENANCE**
- 5. TROUBLE SHOOTING GUIDE**
- 6. ASSEMBLIES, PARTS LISTING & EXPLODED VIEW**

**BLAST POT SERIAL NUMBER:**

## 1.0 GENERAL INFORMATION

### 1.1 Panblast notice to purchasers and users

1.1.1 All products and equipment designed and manufactured by Panblast are intended for use by experienced users of abrasive blasting equipment and its associated operations and abrasive blasting media.

1.1.2 It is the responsibility of the user to:

- Determine if the equipment and abrasive media is suitable for the users' intended use and application.
- Familiarize themselves with any appropriate laws, regulations and safe work practices, which may apply within the users working environment.
- Provide appropriate operator training and a safe working environment including operator protective equipment (PPE) such as, but not limited to, safety footwear, protective eyewear and hearing protection.

1.1.3 Panblast Standard Terms and Conditions of Sale apply. Contact your local Panblast office should you require any further information or assistance.

1.2  **! WARNING! - READ THIS SECTION CAREFULLY BEFORE USING THIS EQUIPMENT/APPARATUS.**

1.2.1 Heavy metal paint, asbestos and other toxic material dusts will cause serious lung disease or death without the use of properly designed and approved supplied air respiratory equipment (SAR) by blast operators and all personnel within the work site area.

1.2.2 The compressor must have adequate output and the plumbing between the compressor and the point of attaching the air supply hose must have sufficient capacity to supply the volume of air at the pressure required.

### 1.3 Standard safety precautions

1.3.1 Approved safety eyewear, hearing and footwear protection should be worn at all times by the operator and anyone else in the immediate area that may be exposed to any hazards generated by the abrasive blasting process.

1.3.2 Suitably approved respiratory protection should also be worn when handling abrasive media, abrasive refuse dust and when carrying out any service/maintenance work where any dust may be present.

1.3.3 Any work performed on electrical wiring or components must only be carried out by suitably qualified and registered electrical trades personnel.

1.3.4 Under no circumstances should any safety interlocks/lockouts or features be altered or disabled in any way.

1.3.5 All equipment must be isolated from the compressed air supply and electrical power prior to any service or maintenance work being carried out.

1.3.6 All care must be taken by the operator(s) when lifting or moving equipment or components in order to prevent injury. Blast pots must always be emptied of abrasive media before any attempt is made to move them.

1.3.7 Any modification of the equipment and/or components or use of non-genuine PanBlast™ replacement parts will void warranty.

1.3.8 Always check the Material Safety Data Sheet (MSDS) on the abrasive media being used to ensure that it is free of harmful substances, in particular, free silica, cyanide, arsenic or lead.

1.3.9 Test the surface to be blasted for harmful substances, taking the appropriate measures to ensure the safety of the operator and others

1.3.10 The operator should carry out a daily inspection of all related components prior to startup of all wearing and safety items to ensure they are in correct operating order.

In particular check all hose couplings and nozzle holders, ensuring that all hose couplings are fitted correctly and the safety locking pins are engaged and in good order. Always install safety whip check cables at every hose connection. Ensure that the blast nozzle has been securely screwed into the nozzle holder and the nozzle holder has been secured to the blast hose correctly and all screws are engaged.

**NOTE: UNDER OSHA 1915:34(c)(1)(iv) DEAD MAN CONTROL. A DEADMAN CONTROL DEVICE SHALL BE PROVIDED AT THE NOZZLE END OF THE BLAST HOSE EITHER TO PROVIDE DIRECT CUTOFF OR TO SIGNAL THE POT TENDER BY MEANS OF A VISUAL AND AUDIBLE SIGNAL TO CUT OFF THE FLOW, IN THE EVENT THE BLASTER LOSES CONTROL OF THE HOSE. THE POT TENDER SHALL BE AVAILABLE AT ALL TIMES TO RESPOND IMMEDIATELY TO THE SIGNAL.**

## 2.0 INITIAL SET UP INSTRUCTIONS

### 2.1 Blast pot initial set up

2.1.1 Position the blast pot in the location where it is to be used, preferably on a flat, level surface. Never attempt to move the blast pot when it is full of abrasive media.

2.1.2 Fit the blast hose coupling and nozzle holder to the blast hose, ensuring that the ends of the blast hose are cut square and flat. The blast hose coupling and nozzle holder must be pushed/twisted up onto the blast hose until the end of the blast hose is firmly up against the inside step located inside the blast hose coupling and nozzle holder. Then install the screws supplied with the blast hose coupling and nozzle holder to ensure that they are securely fitted to the blast hose.

** ! WARNING! - NEVER OPERATE/USE A BLAST HOSE WITHOUT THE BLAST HOSE COUPLING AND NOZZLE HOLDER FITTED IN THE CORRECT MANNER.**

2.1.3 Once fitment of the blast hose fittings is completed, connect the blast hose coupling to the abrasive metering valve coupling located on the bottom of the blast pot, making sure that the coupling safety locking pins are correctly fitted and form an airtight seal between the two couplings. Then lay the blast hose out flat for its full length.

- 2.1.4 Connect the ends of the twinline hose quick connect couplings to the remote control valve on the blast pot. Then lay the twinline hose out alongside the blast hose for its full length.
- 2.1.5 Using cable ties, heavy tape or similar, attach the twinline hose directly to the blast hose at approximately 1000mm (40") intervals. The remote control handle should be cable tied to the blast hose at a point directly behind the previously fitted nozzle holder.
- 2.1.6 Securely attach a suitably sized compressed air line to the blast pot main isolation ball valve, ensuring that the isolation ball valve is in the closed position. It is preferable for the compressed air line to be at least one size larger than the piping size on the blast pot. Ensure that all coupling safety locking pins and/or locks are correctly fitted to the compressed air connection. PanBlast recommends the use of a correctly sized safety whip check cables to all compressed air line connection points.
- 2.1.7 Check that the nozzle holder rubber washer is correctly installed then screw the blast nozzle fully into the nozzle holder, ensuring that it forms a seal against the nozzle rubber washer.
- 2.1.8 The blast pot is now ready for operation.

### 3.0 OPERATING INSTRUCTIONS

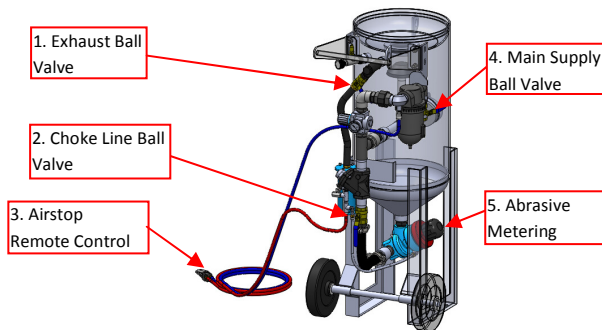

Figure A

#### 3.1 Blast pot operating instructions

- 3.1.1 Ensure that the blast pot has been set up as detailed in section 2.0 of this manual.
- 3.1.2 Check that the twinline hose connections to the blast pot are configured as outlined in 2.1.4 of this manual.
- 3.1.3 Check that the main air supply ball valve (Figure A Item 4) is in the closed position and the exhaust ball valve (Figure A Item 1) is in open position
- 3.1.4 Screw the control knob of the Corsa II Abrasive Metering Valve (Figure A Item 5) in a clockwise direction all the way in, noting the position of the control knob; now wind the control knob out in an anticlockwise direction 4 turns. This provides an initial start position.
- 3.1.5 Load the abrasive media into the blast pot by pouring it in through the pop up valve opening located in the top of the blast pot. The blast pot screen (where supplied) should be used to prevent coarse debris and oversize particles from entering the blast pot.

**⚠ ! WARNING! - DO NOT OVERFILL THE BLAST POT. THE ABRASIVE LEVEL SHOULD REMAIN BELOW THE BOTTOM OF THE POP UP VALVE.**

- 3.1.6 Check the remote control handle (Figure A Item 3), and ensure that the safety lock button is in the out position, and that both the lever and safety lock button move and engage freely.
- 3.1.7 Check that all hose connections, fittings, safety locking pins etc. are all secure and in the proper location.
- 3.1.8 Start the air compressor, and allow the compressor to reach the desired operating pressure. Do not set the blast pressure below 345Kpa (50psi) as the blast system may not operate correctly (this is to ensure that the pop up valve is fully operational and closes)

**⚠ ! WARNING! - DO NOT EXCEED THE MAXIMUM OPERATING PRESSURE OF THE BLAST POT**

**⚠ ! WARNING! - INCOMING MINIMUM COMPRESSED AIR PRESSURE MUST BE AT LEAST 90PSI FOR THE CORSA VALVE TO BE FUNCTIONAL**

- 3.1.9 Close the exhaust ball valve before opening the main supply ball valve on the blast pot. Then open the choke line ball valve (Figure A Item 2).
- 3.1.10 Set the blasting pressure by adjusting the inlet pressure regulator. Do not set the blast pressure below 345Kpa (50psi) as the blast system may not operate correctly. The pop up valve may not pop up and seal if the pressure is below 50psi.
- 3.1.11 Check the piping for air leaks.

**NOTE: THE BLAST POT IS NOW PRESSURIZED. THE SYSTEM IS READY TO OPERATE. THE OPERATOR SHOULD WEAR APPROVED SUPPLIED AIR RESPIRATORY EQUIPMENT (SAR) AND APPROPRIATE BODY PROTECTION GEAR BEFORE ACTIVATING THE BLASTING MACHINE.**

- 3.1.12 Pick up the blast hose at the blast nozzle end, and direct the blast nozzle at the surface/part to be abrasive blasted.
- 3.1.13 Depress the safety lock button on the remote control handle and then depress the lever handle. After a few moments, the Tandem Remote Valve and the Corsa II Abrasive Metering Valve will activate and the abrasive blasting process will commence.
- 3.1.14 Now run a test blast to check if the Corsa II Abrasives Metering Valve flow setting is correct, the flow from the blast nozzle should slightly discolor a light or contrasting background.
- 3.1.15 If no discoloration is evident and there is a high pitched sound from the blast nozzle, then the adjustment is lean and the abrasive flow needs to be increased by further opening the Corsa II Valve, this should be done in 1/4 turn increments in an anticlockwise direction until the correct abrasive media flow is achieved.
- 3.1.16 If the abrasive feed to the blast nozzle is erratic and surging, then the feed is too rich and the abrasive flow needs to be decreased, again in 1/4

turn increments in a clockwise direction until the correct flow is achieved.

- 3.1.17 To stop blasting, release the remote control handle lever. This will de-energize the Tandem Remote Control Valve and the Corsa II Abrasive Metering Valve will automatically close, which will stop both the abrasive and air flow to the blasting nozzle. The blast pot itself will remain pressurized.

### 3.2 Shutdown procedure

- 3.2.1 Close the main air inlet supply ball valve and open the exhaust ball valve. The blast pot will now depressurize / exhaust the compressed air within the blast pot through the exhaust muffler
- 3.2.2 Shut down the air compressor.
- 3.2.3 Cover the blast pot with the lid (where supplied) and coil up and store the blast hose and twin line assembly to prevent accidental damage.

## 4.0 MAINTENANCE

**⚠ ! WARNING! – THE COMPRESSED AIR SOURCE MUST BE ISOLATED BEFORE PERFORMING ANY MAINTENANCE WORK. FAILURE TO DO SO MAY CAUSE SERIOUS INJURY OR DEATH.**

### 4.1 On a daily basis

- 4.1.1 If fitted, drain any water/moisture from the moisture separator by opening the drain valve located on the bottom of the water trap bowl. Unscrew the retaining ring and remove the water trap bowl. Check the filter element for blockages and replace as required. Re-fit the bowl and locking ring, and closes the bowl drain valve.

**NOTE: IT IS RECOMMENDED THE INCOMING COMPRESSED AIR IS EQUIPPED WITH A DRYER SYSTEM TO ENSURE THE INLET AIR IS DRY.**

- 4.1.2 Inspect the blast hose for wear by feeling along its full length for soft spots which indicate wear, and replace the blast hose as necessary.
- 4.1.3 Check that all blast hose couplings and the nozzle holder are secure and that all safety locking pins are correctly in place.
- 4.1.4 Remove the safety locking pins and disconnect the couplings by twisting the coupling counter clockwise. Inspect the coupling gaskets for wear and correct seating. Replace the gaskets as required. Reconnect the coupling by engaging the lugs with the blast pot coupling and twisting the hose coupling until fully engaged, and then re-fit the safety locking pins.
- 4.1.5 Inspect the AirStop Remote Control Handle, and check that the lever and safety lock button assembly operate correctly, and that the safety lock button prevents operation of the remote control handle when in the deactivated out position.

### 4.2 On a weekly basis

- 4.2.1 Remove the blast nozzle from the nozzle holder by unscrewing the nozzle in a counter clockwise direction, and inspect it for wear. Replace the nozzle when the internal diameter is worn by 1.5mm (1/16") from its original size, or if the inner carbide liner is chipped or cracked.

- 4.2.2 Check the condition of the nozzle washer and replace as required, then re-fit/replace the blast nozzle by screwing it clockwise into the nozzle holder until it is fully sealed against the nozzle washer.

- 4.2.3 Check the condition of the nozzle holder, and inspect for any cracks or signs of damage. Replace if required as detailed in section 2.1.2.

### 4.3 On a monthly basis

- 4.3.1 Inspect the pop up valve located in the top of the blast pot for wear in the form of cracks or grooves. If replacement is required, remove the blast pot shell inspection cover located on the front of the blast pot. Using a suitable pipe wrench, unscrew the vertical pipe section which houses the pop up valve, and remove both the pipe section and pop up valve through the inspection opening. Installation of the new pop up valve is a reversal of the removal procedure which ensures that the pop up valve is positioned directly below the top opening for correct sealing. Refer Figure (B).



Figure B

- 4.3.2 Check and inspect the pop up valve seating ring for wear. If replacement is necessary, use a large screw driver or similar tool to pry the seating ring out of the seat. When re-fitting the new seating ring, ensure that it is correctly seated within the seating ring housing. It is recommended to replace the pop up Valve and seating ring at the same time as a set. Refer Figure (C).



Figure C

- 4.3.3 Inspect the blast pot exhaust muffler and exhaust line for wear or blockages, replace the worn or blocked muffler and exhaust line as necessary.

5.0 TROUBLE SHOOTING GUIDE

Item	Problem	Possible Cause	Corrective Action
1	Blast pot will not pressurize	No / inadequate compressed air supply	Check that air compressor is operational. Ensure air output and supply hose size is correct.
		Main supply ball valve is closed	Open ball valve
		Pop up valve / Seating ring worn or damaged	Inspect & replace as required
		Exhaust ball valve open	Close exhaust ball valve
		Inlet pressure set too low	Adjust pressure regulator to increase pressure.
2	No air and/or abrasive flow from blast nozzle	Blast nozzle blocked	Depressurize system & remove nozzle from nozzle holder
			Check & clear any possible blockage.
			Re-fit blast nozzle
		Choke line ball valve fully closed	Open valve.
		Abrasive metering valve fully closed	Open and adjust the abrasive metering valve as required
		Pop up valve or seating ring worn or damaged	Inspect and replace as required
		Insufficient abrasive in blast pot	Refill with abrasive as required
		Excessive dust and fines in abrasive mix	Drain abrasive from blast pot and refill with clean abrasive
		Tandem Valve not operating	Inspect diaphragm for wear. Replace as necessary.
Damp or wet abrasive in blast pot	Drain abrasive from blast pot and refill with clean abrasive		
3	Intermittent abrasive flow	Excessive dust and fines in abrasive	Drain abrasive from blast pot and refill with clean abrasive
		Insufficient abrasive in blast pot	Refill with abrasive as required
		Damp or wet abrasive in blast pot	Drain abrasive from blast pot and refill with clean abrasive
		Excessive abrasive	Check and adjust pressure regulator as required.
		Compressed air supply pressure too low	
4	Excessive abrasive flow	Abrasive metering valve fully opened	Adjust abrasive metering valve as required
5	Excessive wear on blast hose	Blast hose kinked or coiled	Keep blast hose as straight as possible without being coiled.
		Blast nozzle excessively worn	Check the internal diameter of blast nozzle and replace if necessary.

6.0 ASSEMBLIES, PARTS LISTING & EXPLODED VIEW

6.1 PanBlast™ BP316-2 Manual Blast Pot Assembly

Stock Code	Description	Dry Weight	Abrasive Capacity	Piping Size
BEP-PS-0077-00	BP316-2/NZ/MY Tandem Corsa II-US AirStop	145kg (320lbs)	100 litres (3ft³)	32mm (1-1/4")

6.1.1 PanBlast™ BP316-2 Manual Blast Pot Parts Listing

Item	Stock Code	Description	Qty
1	BAC-RC-PB-0084	AirStop Pneumatic Control Handle	1
2	BAC-RC-PB-0012	20m (66') Twinline Hose Assembly	1
3	BAC-PF-0274-00	1/2" BSP - 125 PSI Pressure Relief Valve	1
4	BAC-PF-PB-0031	6mm (1/4") Pressure Gauge - Rear Entry	1
5	BAC-PF-PB-0003	25mm (1") Ball Valve	1
6	YAC-PF-PB-0152	Hose Barb	1
7	YAC-FN-PB-0242	Hose Clamp	2
8	BAC-AF-PB-0089	25mm(1") Pressure Regulator	1
9	YAC-BF-PB-0041	Hose-Air/Water Delivery 19mmIDx29mmOD	0.4 MTR
10	BAC-RC-PB-0276	1 1/4" Tandem NPT Valve Assembly	1
11	YAC-PF-PB-0167	Mini Ball Valve	1
12	YAC-BF-0337-00	Support Bracket	1
13	YAC-BF-0336-00	Elbow	1
14	BAC-AF-0120-01	32mm (1-1/4") Filter Separator	1
15	BAC-PF-PB-0006	32mm (1-1/4") Ball Valve	2
16	BAC-PF-PB-0007	32mm (1-1/4") Non Return Valve	1
17	BAC-RC-PB-0022	Exhaust Muffler	1
18	YAC-PF-PB-0184	KC Nipple	2
19	YAC-FN-PB-0244	Hose Clamp	2
20	YAC-BF-PB-0046	Hose-Air/Water Delivery 32mmIDx45mmOD	0.55 MTR
21	BAC-HC-PB-0009	NTC-1 Nylon Threaded Pot Coupling	1
22	BAC-VA-PB-0117	Corsa II 1-1/4" With Urethane Sleeve	1
23	YAC-BF-0231-00	Blast Pot-H/Hole 192x144-Sealing Gasket	1
24	BAC-BF-PB-0012	Pop Up Valve - Stem Type	1
25	BAC-BF-PB-0013	Pop Up Valve Seating Ring	1

6.1.2 PanBlast™ BP316-2 Manual Blast Pot Exploded View

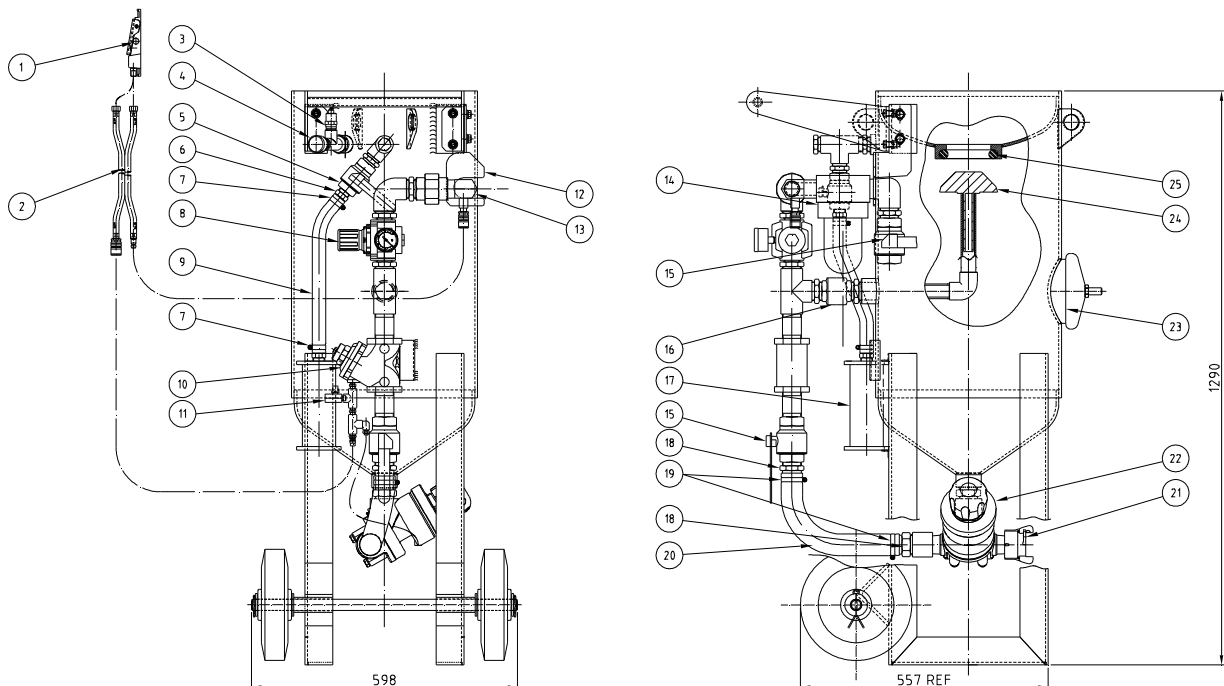

**6.2 1 ¼" Tandem Remote Control Valve Assembly**

Stock Code	Description	Weight
BAC-RC-PB-0276	1 1/4" Tandem NPT Valve Assembly	3.75 Kg (8.27 lbs)

**6.2.1 1 ¼" Tandem Remote Control Valve Parts Listing**

Item	Stock Code	Description	Qty
1	YAC-RC-PB-0280	Cap	1
2	YAC-BS-PB-0041	O-ring	1
3	YAC-RC-PB-0293	Cover	1
4	YAC-FN-PB-0276	Lock Nut	1
5	YAC-FN-PB-0275	Flat Washer	2
6	YAC-RC-PB-0294	Flat Washer	2
7	YAC-RC-PB-0295	Diaphragm	1
8	YAC-RC-PB-0296	Guide Bush	1
9	YAC-BS-PB-0045	O-ring	1
10	YAC-BS-PB-0044	O-ring	1
11	YAC-RC-PB-0297	Connecting Shaft	1
12	YAC-FN-PB-0274	Flat Washer	1
13	YAC-RC-PB-0298	Gasket Holder	1
14	YAC-RC-PB-0299	Rubber Gasket	1
15	YAC-RC-PB-0300	Retainer	1
16	YAC-FN-PB-0273	Lock Nut	1
17	YAC-RC-PB-0301	Inner Bush	1
18	YAC-BS-PB-0046	O-ring	1
19	YAC-RC-PB-0303	Body	1
20	YAC-FN-PB-0118	Spring Washer	4
21	YAC-FN-PB-0218	Nut	4
22	YAC-FN-PB-0284	Screw	4
23	YAC-RC-PB-0302	Spring	1

**6.2.2 1 ¼" Tandem Remote Control Valve Service Kits**

Stock Code	Description
BAC-RC-PB-0279	1-1/4" & 1-1/2" Tandem Valve Service Kit - Includes Items: 2, 4, 5 (2 Off), 7, 9, 10, 12, 14, 16 & 18
BAC-RC-0536-00	Tandem Valve 1-1/4" & 1-1/2" Repair Kit - Includes Items: 2, 6, 7, 10, 11, 12 (3 Off), 14, 15, 18 & 20 (4 Off)



6.2.3 1 1/4" Tandem Remote Control Valve Exploded View

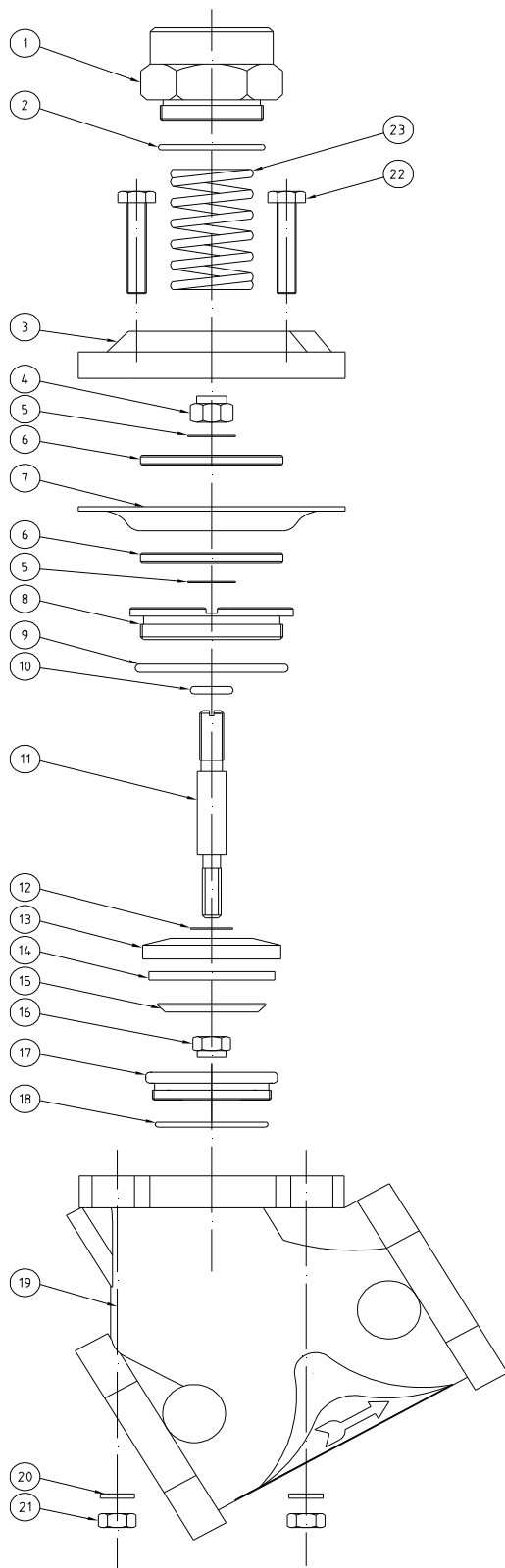

### 6.3 AirStop BSP Pneumatic Control Handle Assembly

Stock Code	Description	Weight
BAC-RC-PB-0084	Airstop Pneumatic Control Handle	0.28Kg (0.62lbs)

#### 6.3.1 AirStop BSP Pneumatic Control Handle Parts Listing

Item	Stock Code	Description	Qty
1	YAC-RC-PB-0048	Lever	1
2	YAC-RC-PB-0049	Body	1
3	YAC-RC-PB-0050	Plunger Plug	2
4	YAC-RC-PB-0051	Hinge Pin	1
5	YAC-FN-0352-00	Screw	1
6	YAC-RC-PB-0053	Button	1
7	YAC-RC-PB-0054	Spring	1
8	YAC-FN-PB-0164	Screw	1
9	YAC-FN-PB-0048	Flat Washer	1
10	YAC-RC-PB-0087	Nipple - Un-Restricted	2
11	YAC-RC-PB-0056	Plunger Sleeve	1
12	YAC-RC-PB-0057	Plunger	1
13	YAC-BS-PB-0013	O-Ring	2

#### 6.3.2 AirStop BSP/NPT Pneumatic Control Handle Service Kit

Stock Code	Description
BAC-RC-PB-0093	AirStop Service Kit - Includes Items: 3(2 Off), 5, 7, 8, 11, 12 , 13(2 Off)

### 6.3.3 AirStop BSP Pneumatic Control Handle Exploded View

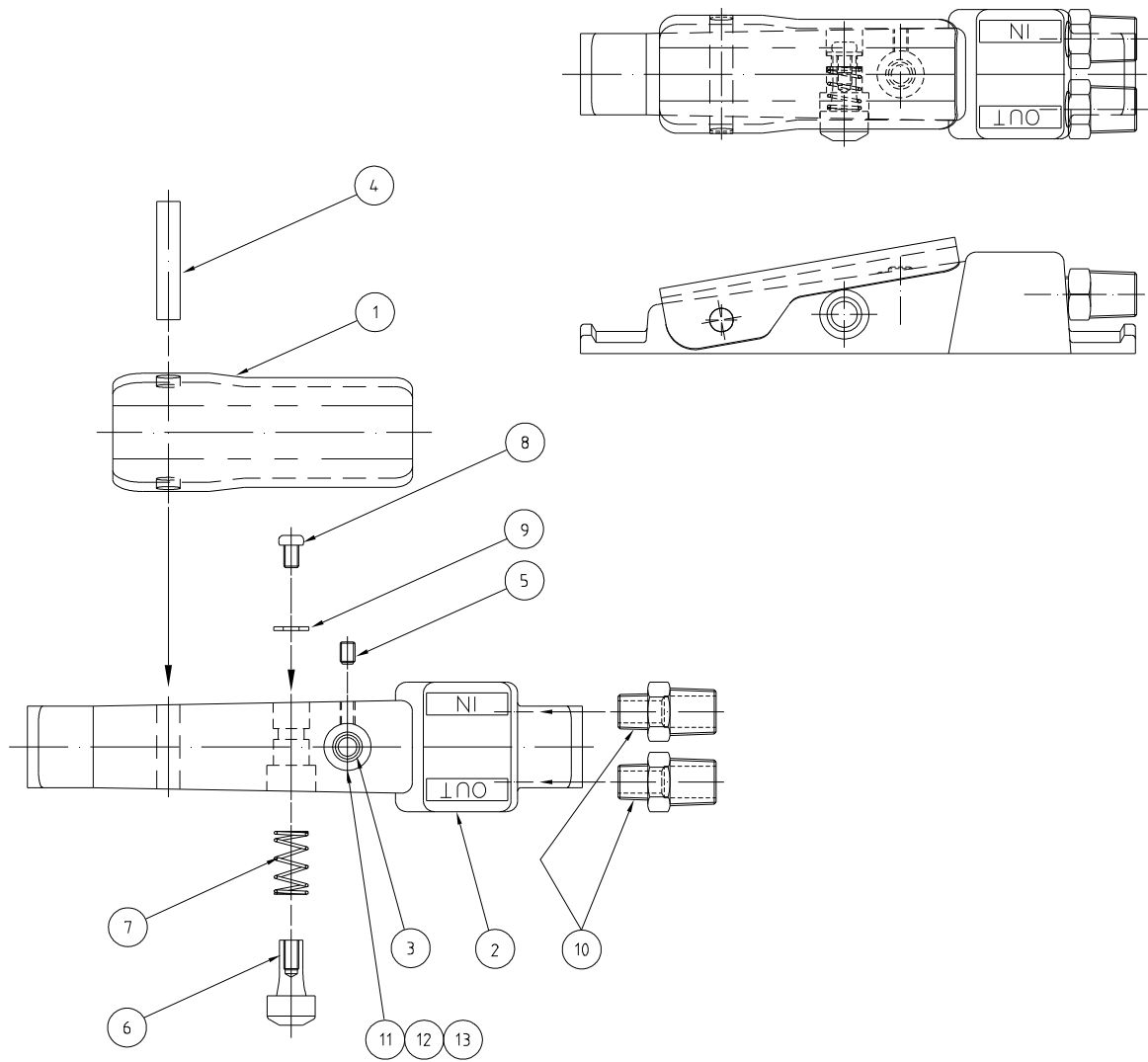

#### 6.4 Corsa II Valve with Urethane Sleeve Assembly

Stock Code	Description	Weight
BAC-VA-PB-0117	Corsa II 1-1/4" With Urethane Sleeve	5.9 Kg (12.98 lbs)

##### 6.4.1 Corsa II Valve with Urethane Sleeve Parts Listing

Item	Stock Code	Description	Qty
1	BAC-VA-PB-0093	Top Cover	1
2	YAC-VA-PB-0095	Anti Vibration Washer	1
3	YAC-VA-PB-0094	Stop Ring	1
4	YAC-VA-PB-0096	Spring	1
5	YAC-VA-PB-0097	Piston Seal	1
6	YAC-VA-PB-0124	Plunger Cover	1
7	YAC-VA-PB-0137	Nylon Washer	1
8	YAC-VA-PB-0098	Piston	1
9	BAC-VA-PB-0099	Tungsten Plunger	1
10	BAC-VA-PB-0100	Cylinder	1
11	YAC-VA-PB-0052	Plunger Seal	4
12	YAC-BS-PB-0032	O-Ring	2
13	YAC-VA-PB-0125	Bush	1
14	YAC-VA-PB-0120	Urethane Sleeve	1
15	YAC-VA-PB-0194	Base	1
16	YAC-FN-PB-0258	Flat Washer	4
17	YAC-FN-PB-0104	Hex Head Bolt	4
18	BAC-AF-PB-0163	Exhaust Filter	1
19	YAC-PF-PB-0231	Plug - Stainless Steel	1
20	BAC-VA-PB-0092	Control Knob	1
21	BAC-VA-PB-0090	Corsa 1-1/4"M X 1-1/4"M Pipe Nipple	1
22	BAC-VA-PB-0091	Corsa 1-1/2"M X 1-1/2"M Pipe Nipple	1

##### 6.4.2 Corsa II Valve with Urethane Sleeve Service Kits

Stock Code	Description
BAC-VA-PB-0119	Corsa II Urethane Seal Kit - Includes Items: 5, 11, 12, 13, 14
BAC-VA-PB-0139	Corsa II Piston Kit - Includes Items: 2, 3, 4, 5, 6, 7, 8
BAC-VA-PB-0140	Corsa II Valve Base Kit - Includes Items: 15, 16, 17

6.4.3 Corsa II Valve with Urethane Sleeve Product Exploded View

